

HETERO JUNCTION FIELD EFFECT TRANSISTOR NE32584C

C to Ku BAND SUPER LOW NOISE AMPLIFIER N-CHANNEL HJ-FET

DESCRIPTION

The NE32584C is a Hetero Junction FET that utilizes the hetero junction to create high mobility electrons. Its excellent low noise and high associated gain make it suitable for DBS, TVRO and another commercial systems.

FEATURES

- Super Low Noise Figure & High Associated Gain
NF = 0.45 dB TYP., $G_a = 12.5$ dB TYP. at $f = 12$ GHz
- Gate Length : $L_g \leq 0.2 \mu\text{m}$
- Gate Width .. : $W_g = 200 \mu\text{m}$

ORDERING INFORMATION

PART NUMBER	SUPPLYING FORM	LEAD LENGTH	MARKING
NE32584C-SL	STICK	$L = 1.7$ mm MIN.	D
NE32584C-T1	Tape & reel 1000 pcs./reel	$L = 1.0 \pm 0.2$ mm	
NE32584C-T1A	Tape & reel 5000 pcs./reel	$L = 1.0 \pm 0.2$ mm	

ABSOLUTE MAXIMUM RATINGS ($T_A = 25^\circ\text{C}$)

Drain to Source Voltage	V_{DS}	4.0	V
Gate to Source Voltage	V_{GS}	-3.0	V
Drain Current	I_D	I_{DSS}	mA
Gate Current	I_G	100	μA
Total Power Dissipation	P_{tot}	165	mW
Channel Temperature	T_{ch}	150	$^\circ\text{C}$
Storage Temperature	T_{stg}	-65 to +150	$^\circ\text{C}$

RECOMMENDED OPERATING CONDITION ($T_A = 25^\circ\text{C}$)

CHARACTERISTIC	SYMBOL	MIN.	TYP.	MAX.	Unit
Drain to Source Voltage	V_{DS}		2	3	V
Drain Current	I_D		10	20	mA
Input Power	P_{in}			0	dBm

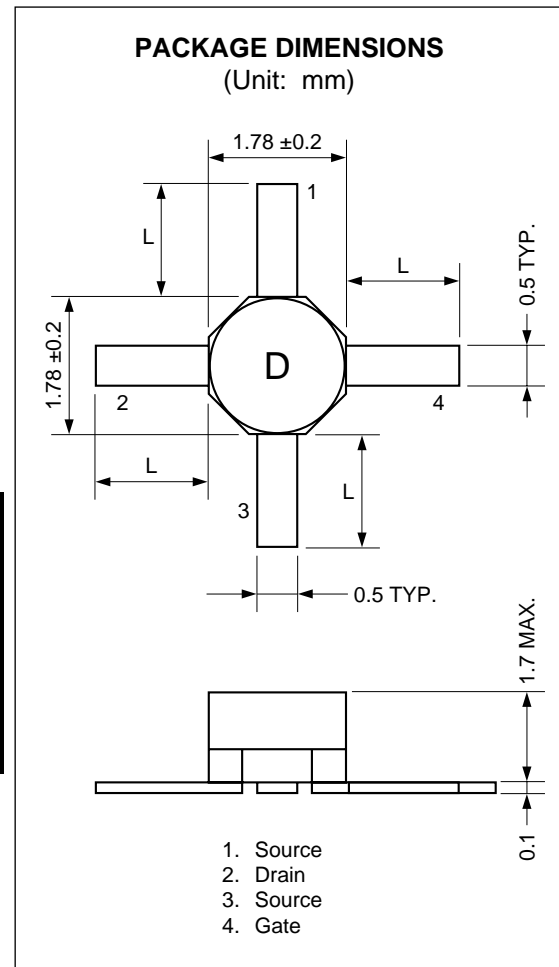

ELECTRICAL CHARACTERISTICS (T_A = 25 °C)

CHARACTERISTIC	SYMBOL	MIN.	TYP.	MAX.	UNIT	TEST CONDITIONS
Gate to Source Leak Current	I _{GSO}		0.5	10	μA	V _{GS} = -3 V
Saturated Drain Current	I _{DSS}	20	60	90	mA	V _{DS} = 2 V, V _{GS} = 0 V
Gate to Source Cutoff Voltage	V _{GS(off)}	-0.2	-0.7	-2.0	V	V _{DS} = 2 V, I _D = 100 μA
Transconductance	g _m	45	60		mS	V _{DS} = 2 V, I _D = 10 mA
Noise Figure	NF		0.45	0.55	dB	V _{DS} = 2 V, I _D = 10 mA, f = 12 GHz
Associated Gain	G _a	11.0	12.5		dB	

TYPICAL CHARACTERISTICS (T_A = 25 °C)

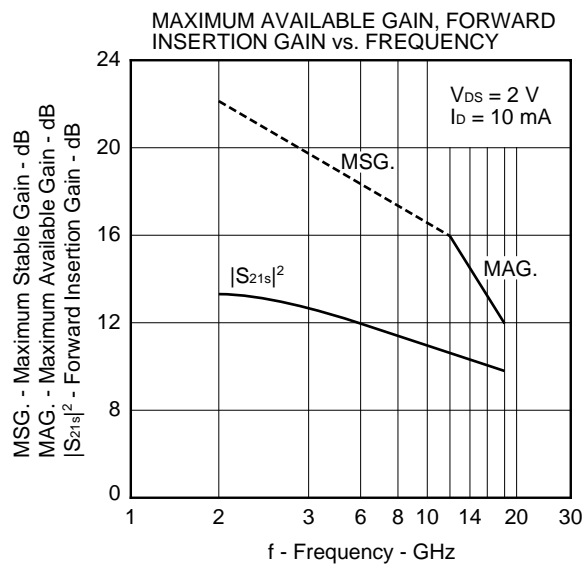
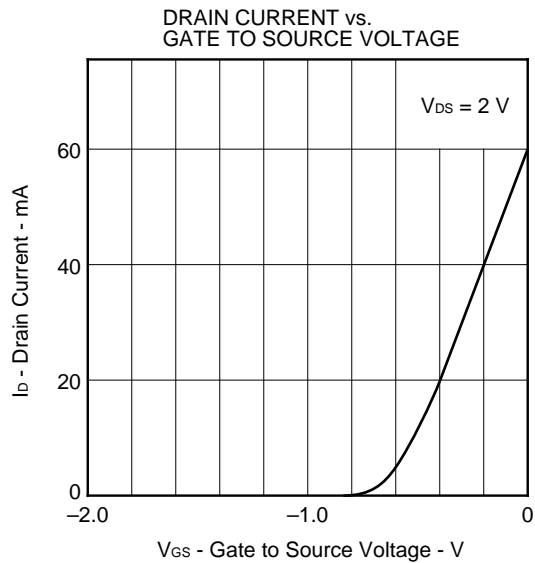
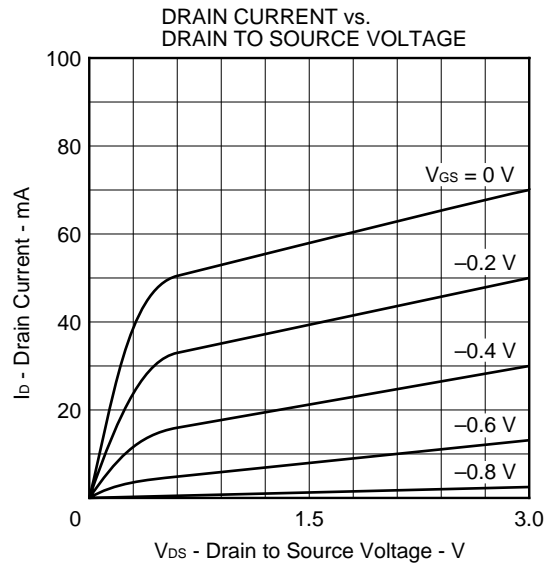
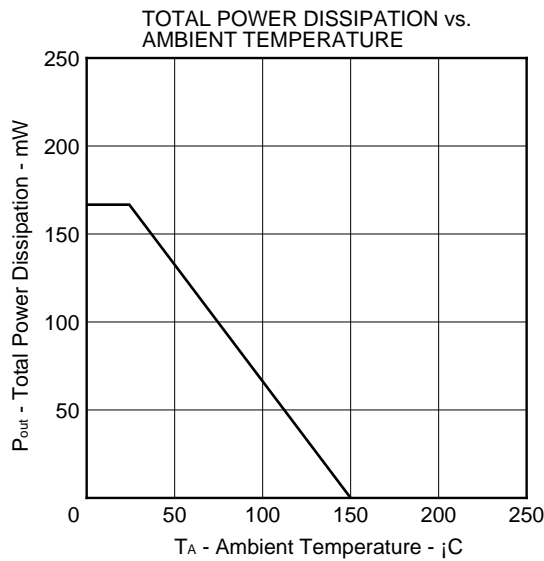

Gain Calculations

$$MSG. = \frac{|S_{21}|}{|S_{12}|}$$

$$K = \frac{1 + |\Delta|^2 - |S_{11}|^2 - |S_{22}|^2}{2|S_{12}||S_{21}|}$$

$$MAG. = \frac{|S_{21}|}{|S_{12}|} (K \pm \sqrt{K^2 - 1})$$

$$\Delta = S_{11} \cdot S_{22} - S_{21} \cdot S_{12}$$

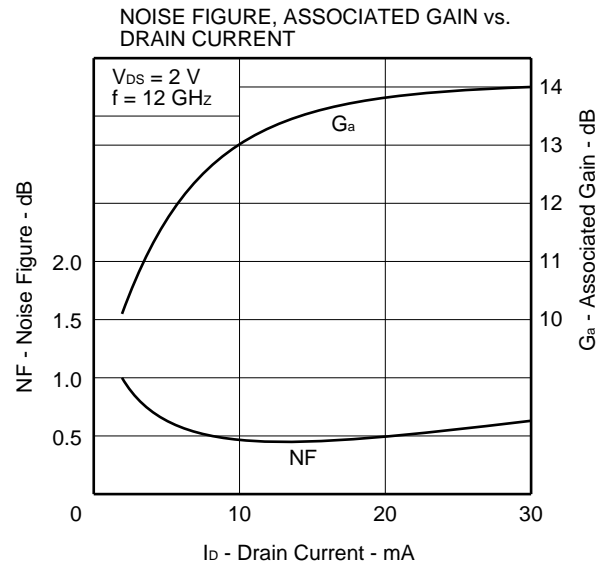
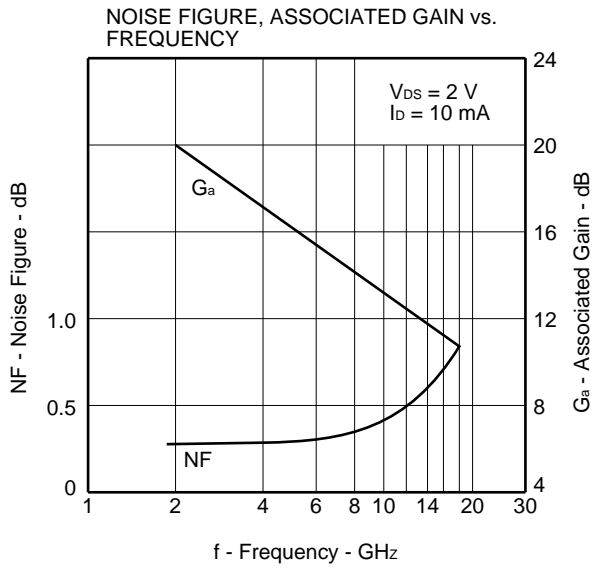

S-PARAMETERS

$V_{DS} = 2\text{ V}$, $I_D = 10\text{ mA}$

START 2 GHz, STOP 18 GHz, STEP 500 MHz

Marker

1 : 4 GHz

2 : 8 GHz

3 : 12 GHz

4 : 16 GHz

5 : 18 GHz

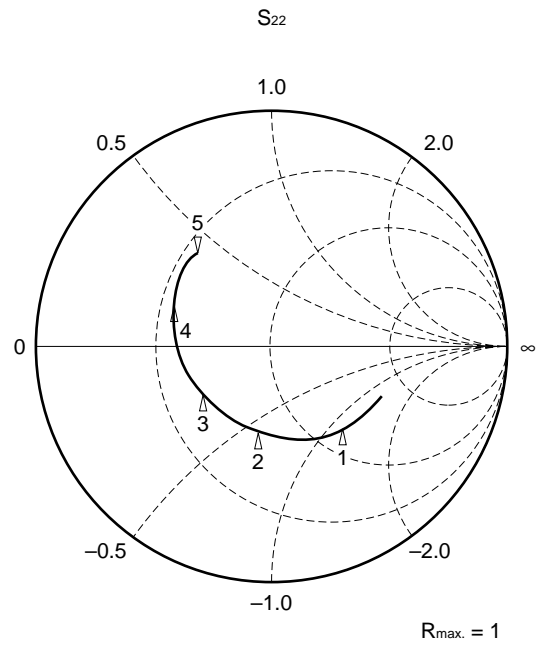
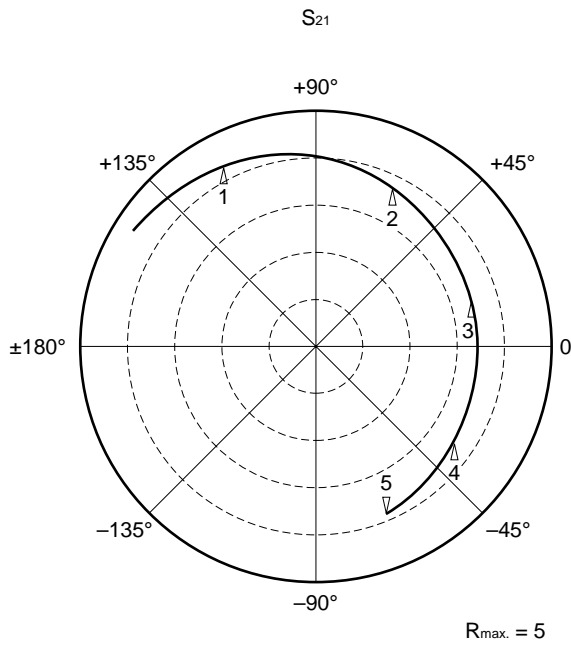
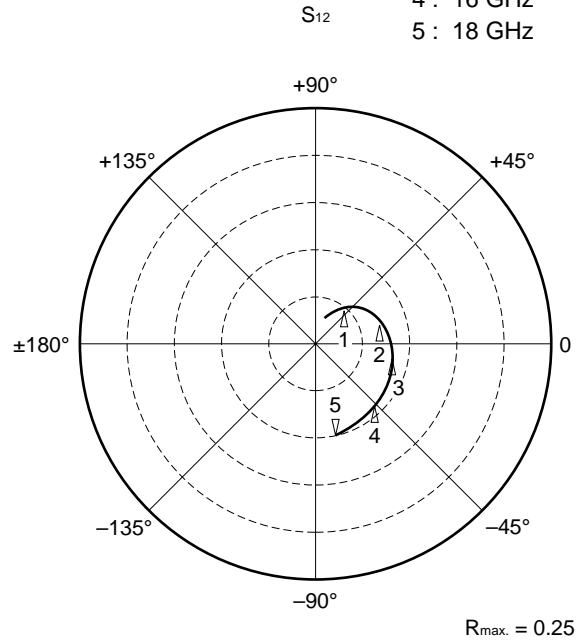
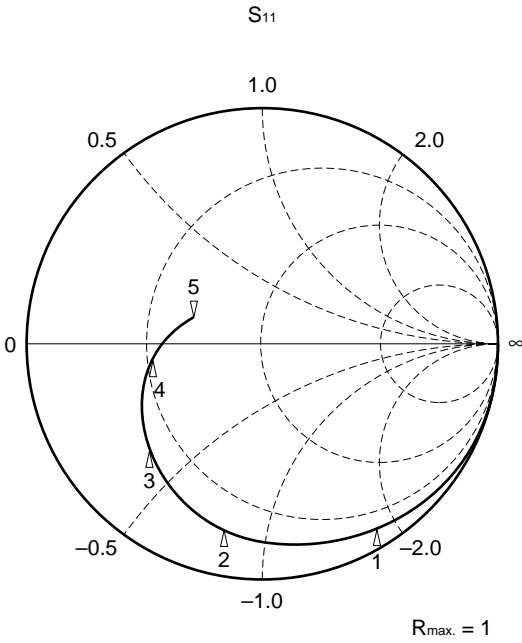

S-PARAMETER

MAG. AND ANG.

V_{DS} = 2 V, I_D = 10 mA

FREQUENCY GHz	S ₁₁		S ₂₁		S ₁₂		S ₂₂	
	MAG.	ANG. (deg.)	MAG.	ANG. (deg.)	MAG.	ANG. (deg.)	MAG.	ANG. (deg.)
2.0	.983	-29.7	4.648	148.4	.027	69.0	.532	-22.6
2.5	.973	-37.2	4.590	140.5	.033	65.3	.520	-28.3
3.0	.960	-43.9	4.543	133.2	.038	60.2	.508	-33.3
3.5	.943	-51.0	4.428	125.8	.044	55.7	.491	-39.3
4.0	.922	-58.0	4.351	118.2	.049	50.2	.472	-45.1
4.5	.912	-64.2	4.296	111.3	.054	45.6	.458	-51.3
5.0	.890	-70.4	4.174	104.5	.057	41.6	.442	-57.3
5.5	.870	-76.4	4.119	97.4	.062	37.7	.428	-63.6
6.0	.856	-81.8	4.005	91.0	.064	32.7	.416	-70.1
6.5	.840	-87.6	3.940	84.1	.068	29.7	.403	-76.0
7.0	.827	-92.5	3.877	78.1	.069	25.1	.395	-82.4
7.5	.816	-97.6	3.805	71.4	.072	21.8	.385	-88.5
8.0	.801	-102.3	3.720	65.3	.074	18.4	.376	-94.0
8.5	.784	-107.5	3.665	58.8	.075	14.9	.372	-99.9
9.0	.776	-112.1	3.604	52.6	.075	11.0	.364	-105.2
9.5	.752	-116.4	3.529	47.0	.077	9.0	.359	-112.7
10.0	.734	-119.8	3.491	41.5	.078	4.9	.357	-118.8
10.5	.713	-124.8	3.435	35.6	.079	2.5	.351	-126.0
11.0	.702	-128.1	3.438	29.7	.082	-1.5	.353	-133.7
11.5	.685	-131.7	3.434	24.0	.084	-5.9	.352	-140.6
12.0	.670	-136.1	3.429	17.6	.084	-8.4	.357	-147.5
12.5	.649	-139.7	3.443	11.6	.085	-12.8	.364	-155.0
13.0	.632	-143.8	3.423	5.1	.085	-17.3	.373	-161.3
13.5	.607	-148.2	3.414	-1.6	.086	-22.1	.384	-168.0
14.0	.588	-151.5	3.416	-7.5	.086	-25.3	.393	-174.7
14.5	.559	-156.1	3.443	-14.1	.088	-28.8	.406	178.1
15.0	.535	-161.6	3.462	-20.8	.089	-34.2	.422	171.4
15.5	.506	-165.4	3.519	-27.4	.092	-39.4	.437	164.2
16.0	.474	-171.6	3.564	-34.3	.092	-43.6	.451	156.3
16.5	.445	-177.1	3.644	-41.8	.095	-52.4	.466	150.0
17.0	.397	175.6	3.678	-49.8	.097	-58.3	.483	142.0
17.5	.356	167.7	3.754	-58.6	.097	-66.4	.484	134.8
18.0	.299	157.7	3.792	-67.6	.094	-74.5	.488	126.3

AMP. PARAMETERS

V_{DS} = 2 V, I_D = 10 mA

FREQUENCY	G _{Umax.}	G _{Amax.}	S ₂₁ ²	S ₁₂ ²	K	Delay	Mason'sU	G ₁	G ₂
GHz	dB	dB	dB	dB		ns	dB	dB	dB
2.0	29.58		13.35	-31.40	.16	.044		14.79	1.44
2.5	27.27		13.24	-29.58	.19	.044		12.67	1.37
3.0	25.46		13.15	-28.44	.25	.040		11.02	1.30
3.5	23.65		12.93	-27.10	.30	.041		9.53	1.20
4.0	22.13		12.77	-26.26	.37	.042		8.26	1.09
4.5	21.43		12.66	-25.40	.39	.039		7.74	1.02
5.0	20.16		12.41	-24.82	.44	.038		6.81	.94
5.5	19.32		12.29	-24.18	.48	.039		6.14	.88
6.0	18.62		12.05	-23.83	.52	.036		5.74	.83
6.5	18.00		11.91	-23.39	.55	.038		5.32	.77
7.0	17.50		11.77	-23.16	.59	.034		5.00	.74
7.5	17.07		11.61	-22.83	.60	.037		4.76	.70
8.0	16.53		11.41	-22.62	.64	.034		4.46	.66
8.5	16.06		11.28	-22.46	.68	.036		4.13	.65
9.0	15.75		11.14	-22.44	.72	.035		4.00	.62
9.5	15.18		10.95	-22.27	.76	.031		3.62	.60
10.0	14.81		10.86	-22.21	.81	.030	34.849	3.36	.59
10.5	14.38		10.72	-22.02	.85	.033	34.181	3.09	.57
11.0	14.25		10.73	-21.68	.84	.033		2.95	.58
11.5	14.04		10.72	-21.53	.87	.032		2.75	.57
12.0	13.88		10.70	-21.55	.89	.035		2.59	.59
12.5	13.73		10.74	-21.41	.91	.034		2.38	.62
13.0	13.56		10.69	-21.36	.94	.036	31.704	2.22	.65
13.5	13.35		10.66	-21.34	.98	.037	26.609	1.99	.69
14.0	13.24		10.67	-21.32	1.00	.033	26.243	1.85	.73
14.5	13.15	15.61	10.74	-21.11	1.00	.037	27.185	1.63	.78
15.0	13.10	15.71	10.79	-21.05	1.01	.037	26.453	1.46	.85
15.5	13.14	15.59	10.93	-20.76	1.00	.036	28.874	1.29	.92
16.0	13.13	15.26	11.04	-20.77	1.01	.039	28.826	1.11	.99
16.5	13.25	15.65	11.23	-20.46	1.00	.042	30.042	.96	1.06
17.0	13.21	15.45	11.31	-20.25	1.00	.044	31.112	.75	1.16
17.5	13.24	14.73	11.49	-20.28	1.04	.049	26.111	.59	1.16
18.0	13.16	14.20	11.58	-20.55	1.09	.050	22.789	.41	1.18

S-PARAMETER

MAG. AND ANG.

V_{DS} = 2 V, I_D = 15 mA

FREQUENCY GHz	S ₁₁		S ₂₁		S ₁₂		S ₂₂	
	MAG.	ANG. (deg.)	MAG.	ANG. (deg.)	MAG.	ANG. (deg.)	MAG.	ANG. (deg.)
2.0	.981	-30.4	5.265	147.5	.062	71.1	.484	-21.9
3.0	.955	-44.8	5.113	132.2	.037	60.9	.460	-32.3
4.0	.911	-59.0	4.878	116.9	.047	52.4	.426	-43.9
5.0	.877	-71.4	4.647	103.2	.055	43.1	.396	-55.2
6.0	.839	-82.9	4.432	89.7	.061	35.6	.371	-67.4
7.0	.809	-93.5	4.268	76.8	.067	28.1	.351	-79.2
8.0	.781	-103.1	4.085	64.1	.070	22.6	.334	-90.4
9.0	.752	-112.7	3.942	51.5	.075	15.5	.325	-101.0
10.0	.710	-120.6	3.805	40.6	.079	9.1	.319	-114.1
11.0	.679	-128.7	3.736	28.7	.082	2.3	.318	-129.0
12.0	.646	-136.2	3.723	16.8	.084	-5.0	.324	-142.9
13.0	.608	-143.9	3.712	4.4	.085	-13.4	.343	-156.3
14.0	.562	-151.5	3.699	-8.2	.088	-20.8	.365	-169.8
15.0	.504	-160.6	3.738	-21.4	.091	-29.5	.395	176.1
16.0	.446	-170.5	3.845	-34.9	.093	-40.4	.429	160.6
17.0	.367	177.0	3.949	-50.4	.096	-54.5	.466	145.5
18.0	.273	160.9	4.050	-68.1	.099	-72.1	.473	130.2

S-PARAMETER

MAG. AND ANG.

V_{DS} = 2 V, I_D = 20 mA

FREQUENCY GHz	S ₁₁		S ₂₁		S ₁₂		S ₂₂	
	MAG.	ANG. (deg.)	MAG.	ANG. (deg.)	MAG.	ANG. (deg.)	MAG.	ANG. (deg.)
2.0	.979	-30.6	5.586	147.1	.025	69.2	.456	-21.4
3.0	.950	-45.1	5.411	131.7	.035	61.0	.431	-31.4
4.0	.907	-59.3	5.136	116.3	.045	52.8	.398	-42.3
5.0	.869	-71.7	4.882	102.6	.053	44.7	.368	-53.4
6.0	.832	-83.2	4.644	89.2	.059	37.0	.345	-65.3
7.0	.801	-93.6	4.459	76.4	.065	30.1	.327	-76.8
8.0	.772	-103.1	4.255	63.7	.070	24.7	.312	-87.4
9.0	.744	-112.8	4.108	51.3	.074	18.1	.303	-97.7
10.0	.702	-120.3	3.958	40.2	.077	11.4	.298	-110.8
11.0	.671	-128.3	3.891	28.5	.082	4.8	.297	-125.7
12.0	.634	-136.0	3.871	16.7	.086	-2.3	.304	-139.0
13.0	.597	-143.3	3.856	4.3	.087	-11.1	.325	-153.3
14.0	.551	-150.5	3.839	-8.2	.090	-18.9	.348	-166.8
15.0	.495	-159.3	3.877	-21.6	.094	-29.0	.384	179.4
16.0	.434	-169.2	3.976	-34.7	.094	-38.0	.421	163.1
17.0	.357	179.6	4.079	-50.2	.098	-53.0	.458	148.0
18.0	.261	164.4	4.195	-67.7	.098	-68.9	.469	132.4

S-PARAMETER

MAG. AND ANG.

V_{DS} = 1 V, I_D = 10 mA

FREQUENCY GHz	S ₁₁		S ₂₁		S ₁₂		S ₂₂	
	MAG.	ANG. (deg.)	MAG.	ANG. (deg.)	MAG.	ANG. (deg.)	MAG.	ANG. (deg.)
2.0	.987	-29.7	4.627	148.3	.028	70.0	.475	-22.4
3.0	.964	-43.9	5.522	133.2	.040	59.5	.451	-33.0
4.0	.927	-58.0	4.335	118.2	.051	50.7	.416	-44.9
5.0	.894	-70.5	4.158	104.5	.060	41.7	.386	-57.0
6.0	.860	-82.0	3.987	91.0	.069	33.0	.361	-69.9
7.0	.833	-92.5	3.854	78.2	.073	25.6	.340	-82.0
8.0	.806	-102.3	3.701	65.4	.078	17.4	.321	-94.2
9.0	.780	-112.3	3.587	52.8	.082	10.4	.310	-105.3
10.0	.739	-120.1	3.475	41.6	.086	4.9	.303	-119.5
11.0	.710	-128.4	3.417	29.8	.090	-3.4	.300	-135.2
12.0	.673	-136.6	3.415	17.7	.092	-11.5	.305	-149.4
13.0	.634	-144.6	3.410	5.3	.092	-19.3	.321	-163.9
14.0	.588	-152.5	3.399	-7.4	.095	-27.4	.342	-177.3
15.0	.532	-162.0	3.455	-20.7	.100	-39.0	.372	168.5
16.0	.473	-172.9	3.557	-34.3	.103	-50.0	.403	152.2
17.0	.392	173.7	3.667	-49.9	.107	-64.7	.435	137.4
18.0	.298	155.7	3.768	-67.9	.111	-80.8	.435	121.6

S-PARAMETER

MAG. AND ANG.

V_{DS} = 3 V, I_D = 10 mA

FREQUENCY GHz	S ₁₁		S ₂₁		S ₁₂		S ₂₂	
	MAG.	ANG. (deg.)	MAG.	ANG. (deg.)	MAG.	ANG. (deg.)	MAG.	ANG. (deg.)
2.0	.989	-29.2	4.146	149.0	.027	69.6	.548	-21.8
3.0	.967	-43.1	4.067	134.1	.038	59.5	.525	-32.5
4.0	.934	-57.2	3.923	119.1	.048	50.5	.492	-44.2
5.0	.901	-69.6	3.779	105.5	.055	41.0	.464	-55.9
6.0	.872	-81.0	3.645	92.0	.062	34.5	.439	-68.9
7.0	.847	-91.7	3.542	79.1	.066	25.9	.420	-81.0
8.0	.823	-101.6	3.412	66.2	.070	19.2	.400	-92.8
9.0	.798	-111.6	3.319	53.5	.071	12.8	.391	-104.0
10.0	.757	-119.4	3.226	42.4	.075	7.3	.382	-117.6
11.0	.730	-127.7	3.183	30.3	.077	0.3	.376	-132.8
12.0	.698	-135.9	3.188	18.2	.081	-6.0	.379	-146.0
13.0	.661	-144.1	3.192	5.7	.081	-13.0	.395	-159.7
14.0	.617	-152.5	3.185	-7.1	.082	-20.4	.415	-172.7
15.0	.561	-162.2	3.239	-20.4	.084	-29.2	.440	173.9
16.0	.503	-173.3	3.353	-33.9	.087	-38.8	.474	159.0
17.0	.428	172.5	3.459	-49.6	.091	-52.5	.506	145.2
18.0	.332	153.5	3.579	-67.5	.092	-68.5	.515	130.6

NOISE PARAMETER

<TYPICAL CONSTANT NOISE FIGURE CIRCLE>

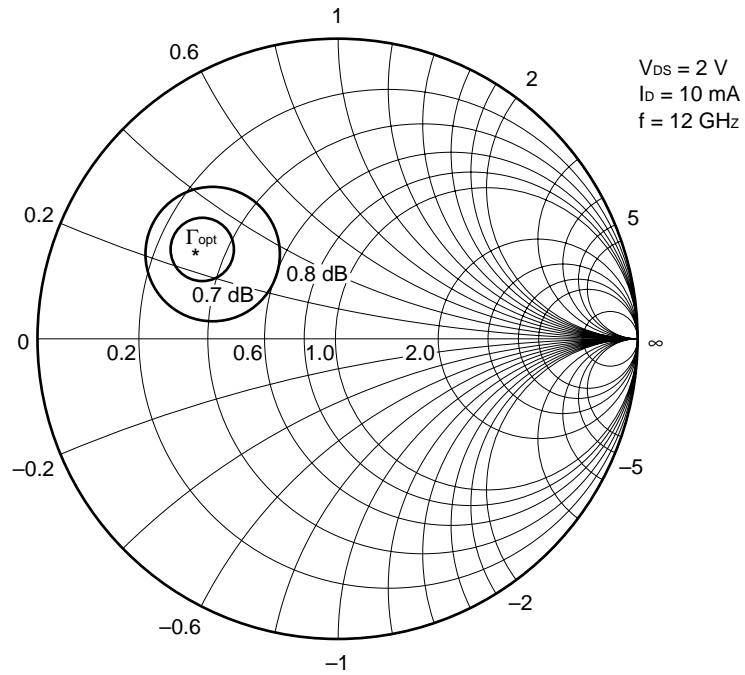

<NOISE PARAMETER>

$V_{DS} = 2 \text{ V}$, $I_D = 10 \text{ mA}$

Freq. (GHz)	NF _{min.} (dB)	G _a (dB)	Γ _{opt.}		R _n /50
			MAG.	ANG. (deg.)	
2.0	0.29	20.0	0.86	22	0.27
4.0	0.30	18.3	0.76	45	0.25
6.0	0.33	16.5	0.69	70	0.18
8.0	0.36	15.0	0.63	96	0.11
10.0	0.40	13.6	0.59	122	0.08
12.0	0.45	12.5	0.54	147	0.04
14.0	0.54	12.0	0.48	171	0.04
16.0	0.68	11.8	0.40	-165	0.05
18.0	0.85	11.5	0.31	-144	0.06

RECOMMENDED SOLDERING CONDITIONS

The following conditions (see table below) must be met when soldering this product.

Please consult with our sales offices in case other soldering process is used, or in case soldering is done under different conditions.

<TYPES OF SURFACE MOUNT DEVICE>

For more details, refer to our document “SEMICONDUCTOR DEVICE MOUNTING TECHNOLOGY MANUAL” (C10535E).

[NE32584C]

Soldering process	Soldering conditions	Symbol
Infrared ray reflow	Peak package's surface temperature: 230 °C or below, Reflow time: 30 seconds or below (210 °C or higher), Number of reflow process: 1, Exposure limit*: None	IR30-00
Partial heating method	Terminal temperature: 230 °C or below, Flow time: 10 seconds or below, Exposure limit*: None	

* Exposure limit before soldering after dry-pack package is opened.
Storage conditions: 25 °C and relative humidity at 65 % or less.

Note Do not apply more than a single process at once, except for “Partial heating method”.

PRECAUTION Avoid high static voltage and electric fields, because this device is Hetero Junction field effect transistor with shottky barrier gate.

Caution

**The Great Care must be taken in dealing with the devices in this guide.
The reason is that the material of the devices is GaAs (Gallium Arsenide), which is designated as harmful substance according to the law concerned.
Keep the law concerned and so on, especially in case of removal.**

[MEMO]

No part of this document may be copied or reproduced in any form or by any means without the prior written consent of NEC Corporation. NEC Corporation assumes no responsibility for any errors which may appear in this document.

NEC Corporation does not assume any liability for infringement of patents, copyrights or other intellectual property rights of third parties by or arising from use of a device described herein or any other liability arising from use of such device. No license, either express, implied or otherwise, is granted under any patents, copyrights or other intellectual property rights of NEC Corporation or others.

While NEC Corporation has been making continuous effort to enhance the reliability of its semiconductor devices, the possibility of defects cannot be eliminated entirely. To minimize risks of damage or injury to persons or property arising from a defect in an NEC semiconductor device, customers must incorporate sufficient safety measures in its design, such as redundancy, fire-containment, and anti-failure features.

NEC devices are classified into the following three quality grades:

"Standard", "Special", and "Specific". The Specific quality grade applies only to devices developed based on a customer designated "quality assurance program" for a specific application. The recommended applications of a device depend on its quality grade, as indicated below. Customers must check the quality grade of each device before using it in a particular application.

Standard: Computers, office equipment, communications equipment, test and measurement equipment, audio and visual equipment, home electronic appliances, machine tools, personal electronic equipment and industrial robots

Special: Transportation equipment (automobiles, trains, ships, etc.), traffic control systems, anti-disaster systems, anti-crime systems, safety equipment and medical equipment (not specifically designed for life support)

Specific: Aircrafts, aerospace equipment, submersible repeaters, nuclear reactor control systems, life support systems or medical equipment for life support, etc.

The quality grade of NEC devices is "Standard" unless otherwise specified in NEC's Data Sheets or Data Books. If customers intend to use NEC devices for applications other than those specified for Standard quality grade, they should contact an NEC sales representative in advance.

Anti-radioactive design is not implemented in this product.

射频和天线设计培训课程推荐

易迪拓培训(www.edatop.com)由数名来自于研发第一线的资深工程师发起成立,致力并专注于微波、射频、天线设计研发人才的培养;我们于 2006 年整合合并微波 EDA 网(www.mweda.com),现已发展成为国内最大的微波射频和天线设计人才培养基地,成功推出多套微波射频以及天线设计经典培训课程和 ADS、HFSS 等专业软件使用培训课程,广受客户好评;并先后与人民邮电出版社、电子工业出版社合作出版了多本专业图书,帮助数万名工程师提升了专业技术能力。客户遍布中兴通讯、研通高频、埃威航电、国人通信等多家国内知名公司,以及台湾工业技术研究院、永业科技、全一电子等多家台湾地区企业。

易迪拓培训课程列表: <http://www.edatop.com/peixun/rfe/129.html>



射频工程师养成培训课程套装

该套装精选了射频专业基础培训课程、射频仿真设计培训课程和射频电路测量培训课程三个类别共 30 门视频培训课程和 3 本图书教材;旨在引领学员全面学习一个射频工程师需要熟悉、理解和掌握的专业知识和研发设计能力。通过套装的学习,能够让学员完全达到和胜任一个合格的射频工程师的要求...

课程网址: <http://www.edatop.com/peixun/rfe/110.html>

ADS 学习培训课程套装

该套装是迄今国内最全面、最权威的 ADS 培训教程,共包含 10 门 ADS 学习培训课程。课程是由具有多年 ADS 使用经验的微波射频与通信系统设计领域资深专家讲解,并多结合设计实例,由浅入深、详细而又全面地讲解了 ADS 在微波射频电路设计、通信系统设计和电磁仿真设计方面的内容。能让您在最短的时间内学会使用 ADS,迅速提升个人技术能力,把 ADS 真正应用到实际研发工作中去,成为 ADS 设计专家...



课程网址: <http://www.edatop.com/peixun/ads/13.html>



HFSS 学习培训课程套装

该套课程套装包含了本站全部 HFSS 培训课程,是迄今国内最全面、最专业的 HFSS 培训教程套装,可以帮助您从零开始,全面深入学习 HFSS 的各项功能和在多个方面的工程应用。购买套装,更可超值赠送 3 个月免费学习答疑,随时解答您学习过程中遇到的棘手问题,让您的 HFSS 学习更加轻松顺畅...

课程网址: <http://www.edatop.com/peixun/hfss/11.html>

CST 学习培训课程套装

该培训套装由易迪拓培训联合微波 EDA 网共同推出,是最全面、系统、专业的 CST 微波工作室培训课程套装,所有课程都由经验丰富的专家授课,视频教学,可以帮助您从零开始,全面系统地学习 CST 微波工作的各项功能及其在微波射频、天线设计等领域的设计应用。且购买该套装,还可超值赠送 3 个月免费学习答疑...

课程网址: <http://www.edatop.com/peixun/cst/24.html>



HFSS 天线设计培训课程套装

套装包含 6 门视频课程和 1 本图书,课程从基础讲起,内容由浅入深,理论介绍和实际操作讲解相结合,全面系统的讲解了 HFSS 天线设计的全过程。是国内最全面、最专业的 HFSS 天线设计课程,可以帮助您快速学习掌握如何使用 HFSS 设计天线,让天线设计不再难...

课程网址: <http://www.edatop.com/peixun/hfss/122.html>

13.56MHz NFC/RFID 线圈天线设计培训课程套装

套装包含 4 门视频培训课程,培训将 13.56MHz 线圈天线设计原理和仿真设计实践相结合,全面系统地讲解了 13.56MHz 线圈天线的工作原理、设计方法、设计考量以及使用 HFSS 和 CST 仿真分析线圈天线的具体操作,同时还介绍了 13.56MHz 线圈天线匹配电路的设计和调试。通过该套课程的学习,可以帮助您快速学习掌握 13.56MHz 线圈天线及其匹配电路的原理、设计和调试...

详情浏览: <http://www.edatop.com/peixun/antenna/116.html>



我们的课程优势:

- ※ 成立于 2004 年,10 多年丰富的行业经验,
- ※ 一直致力并专注于微波射频和天线设计工程师的培养,更了解该行业对人才的要求
- ※ 经验丰富的一线资深工程师讲授,结合实际工程案例,直观、实用、易学

联系我们:

- ※ 易迪拓培训官网: <http://www.edatop.com>
- ※ 微波 EDA 网: <http://www.mweda.com>
- ※ 官方淘宝店: <http://shop36920890.taobao.com>