



# Antenna Modeling Considerations



Arien Sligar

# Antenna Modeling Guidelines: What you need to know



- **Model setup**
  - Creating geometry
  - Excitations
- **Far field considerations**
  - Radiation boundary vs. PML
  - Infinite sphere setup
  - Custom integration surface
- **Solution setup**
  - Solution frequency for adaptive meshing
  - Choosing a reasonable accuracy
  - Output variable convergence
  - Direct solver vs. Iterative solver
  - Higher order basis functions
  - Frequency sweep
- **Post processing**
  - Edit sources
  - Output quantities

## • Creating Geometry

- **2D/3D Metals:** Consider tradeoffs between using 2D vs. 3D metals to model antennas. Typically using 2D objects to represent antenna elements will result in a more efficient simulation without an impact on accuracy. 3D metals are necessary when edge coupling between closely spaced objects is important or when the thickness of the object is on the order of a skin depth.
- **Model Detail:** Apply engineering judgment to determine the level of detail required to accurately represent the antenna geometry. Modeling features that are very small in comparison with a wavelength, such as small holes, chamfers, and blends, may unnecessarily increase the mesh density in areas that are not important to the electromagnetic behavior of the antenna.

## • Excitations

- **Feed Types:** Either Lumped or Wave ports may be used as excitations for antenna simulations. However, certain ports are more suited for particular antenna types. For Example:
  - Waveguides should be fed using wave ports
  - Antennas with differential feeds, such as dipoles and spirals, should be fed using lumped ports
  - Planar antennas fed with coax feeds, microstrip, stripline or other transmission line feeds can use either Wave or Lumped ports
  - Wave ports can be located internal to the solution volume if they are backed by conducting object.

Coaxial antenna feed with coaxial wave port capped by PEC object

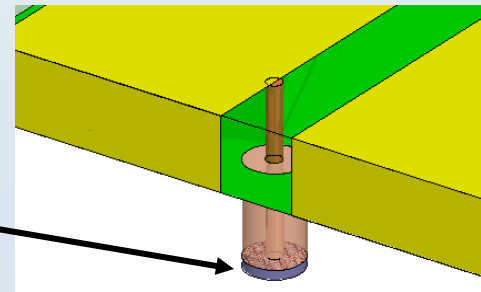

# Far Field Considerations: Radiation vs. PML



**Solution Volume Size:** To properly model the far field behavior of an antenna, an appropriate volume of air must be included in the simulation. Truncation of the solution space is performed by including a radiation or PML boundary condition on the faces of this air volume that mimics free space. The appropriate distance between strongly radiating structures and the nearest face of the air volume depends upon whether a radiation or PML boundary condition is used.

## Radiation Boundary Condition (ABC):

- Absorption achieved via 2nd order radiation boundary
- Place at least  $\lambda/4$  from strongly radiating structure
- Place at least  $\lambda/10$  from weakly radiating structure
- The radiation boundary will reflect varying amounts of energy depending on the incidence angle. The best performance is achieved at normal incidence. Avoid angles greater than  $\sim 30$  degrees. In addition, the radiation boundary must remain convex relative to the wave

## Perfectly Matched Layer (PML):

- Fictitious lossy anisotropic material which fully absorbs electromagnetic fields
- Place at least  $\lambda/8$  from strongly radiating structure
- PML thickness should be approximately  $\lambda/3$  at the lowest frequency of interest
- Does not suffer from incident angle issues

# Far Field Considerations: Infinite Sphere Setup



- The infinite sphere setup specifies a set of spatial data points in a spherical coordinate system for which HFSS will calculate far-fields. To create an infinite sphere setup:
  - Right-click on **Radiation** → **Insert Far Field Setup** → **Infinite Sphere**
- Relative coordinate systems may be used to modify reference orientation in far-field calculations. For example the far field coordinate system does not have to be the same as the global coordinate system.

**Far Field Radiation Sphere Setup**

Infinite Sphere | Coordinate System | Radiation Surface

Name: 3D\_pattern

Phi

Start: 0 deg  
Stop: 180 deg  
Step Size: 5 deg

Theta

Start: -180 deg  
Stop: 180 deg  
Step Size: 2 deg

Save As Defaults View Sweep Points...

OK Cancel Help

**Far Field Radiation Sphere Setup**

Infinite Sphere | Coordinate System | Radiation Surface

Use global coordinate system  
 Use local coordinate system

Choose from existing coordinate systems...

pattern\_CS

Note:  
In order to define local coordinate systems go through the main menu: '3DModeler' -> 'Coordinate System' -> 'Create'

OK Cancel Help

**Far Field Radiation Sphere Setup**

Infinite Sphere | Coordinate System | Radiation Surface

Use Boundary Radiation Surfaces  
 Use Custom Radiation Surface

Choose from existing face list...

Note:  
In order to define custom radiation surfaces. Go through the main menu: '3DModeler' -> 'List' -> 'Create' -> 'Face list'

OK Cancel Help

# Far Field Considerations: Custom Integration Surface



- HFSS calculates far fields using a near to far field transformation. The default integration surfaces for the far-field calculations are faces of radiation boundaries. Radiation surfaces are automatically defined on base object faces of PML objects
- Consider creating custom radiation surface for better accuracy and reduced simulation time. This can be done by creating a “virtual object” having the same properties of the surrounding material. Typically the material is air or vacuum for most antennas.
  - Place an air box at least  $\lambda/10$  from all radiating surfaces
  - Create using **Modeler** → **List** → **Create** → **Face List**
  - Also consider adding a mesh seeding operation with  $\lambda/6$  seeding to the faces of the “virtual air box” to improve far field accuracy.
  - This custom integration surface needs to be specified as a custom radiation surface in the Infinite Sphere setup

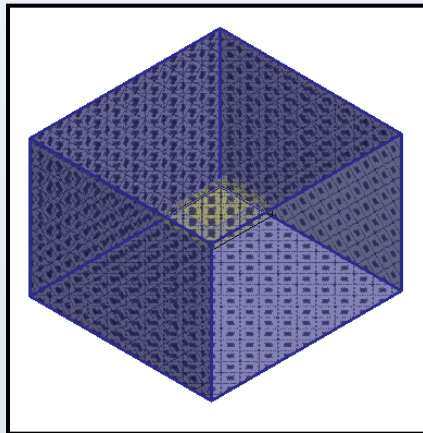

Default Integration Surface

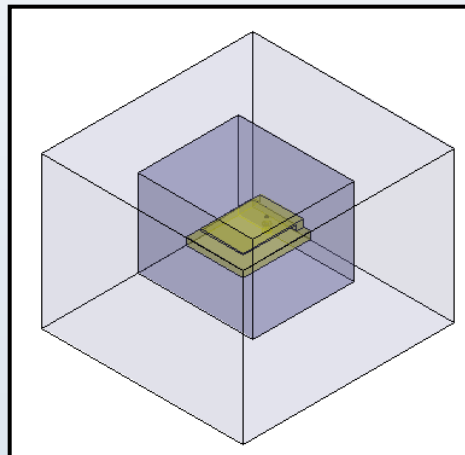

Custom Integration Surface

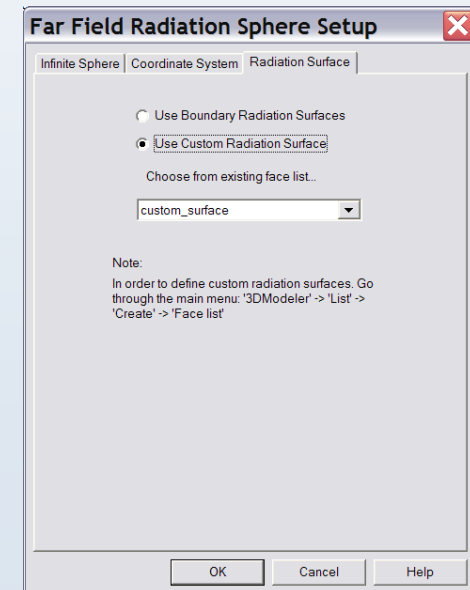

# Solution Setup (1)



- **Solution frequency for adaptive meshing:** The solution frequency sets the frequency at which the adaptive meshing process is performed.

A higher solution frequency yields a more dense initial mesh for the adaptive mesher. A higher frequency mesh is generally valid at lower frequencies, however a low frequency mesh is generally not valid at higher frequencies.

For resonant or narrow band antennas, the solution frequency should be set to the center frequency. For wideband antennas, the solution frequency can typically be set to a frequency in the upper half of the operating band.

- **Choosing a reasonable accuracy:** Set a reasonable maximum  $\Delta S$  convergence value to avoid unnecessary simulation time and RAM usage. A value of 1%-2% is usually sufficient for antenna simulations. Consider the limitations on measurement accuracy when specifying this criterion

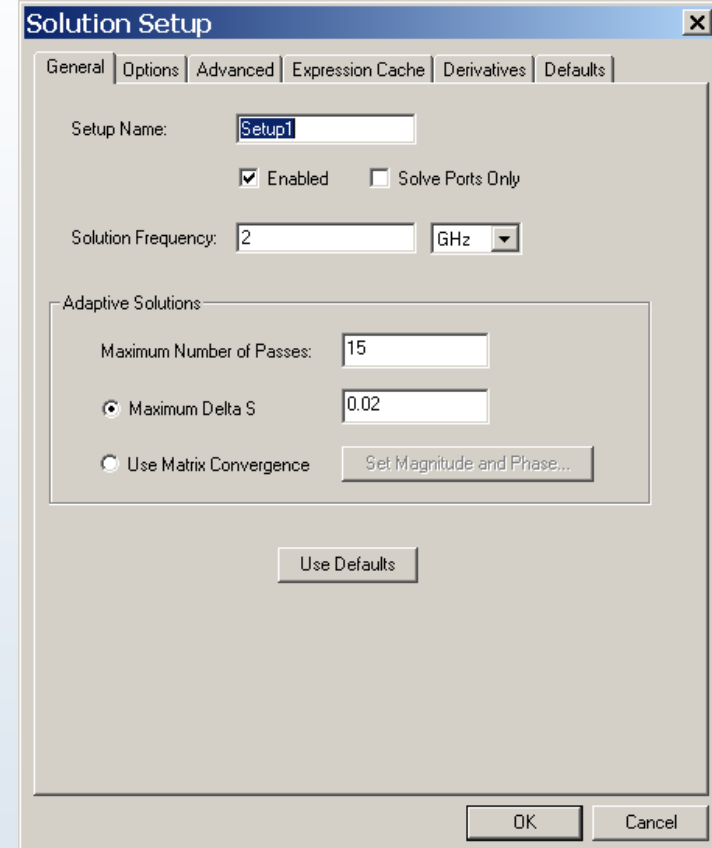



# Solution Setup (2)



- **Expression Cache:** In addition to the  $\Delta S$  convergence criterion used for the adaptive mesher, expressions may be defined which further constrains the stopping point of the adaptive mesh algorithm.

This is useful for antenna models for which far-field parameters are of primary interest. For these models, output variable convergence can be applied on a far-field quantity in order to make sure that the fields have converged as well as the S-parameters.

- **Direct vs iterative matrix solver:** The iterative matrix solver can be used to reduce the RAM necessary to solve the model. This solver uses an iterative solution method to solve the matrix of unknowns. If the iterative solver is not successful, the matrix is solved using the default direct multi-frontal solver.

- **Higher-order basis functions:** Selecting a higher-order basis function may reduce the mesh density through the use of higher-order polynomials to represent the field behavior in each mesh element. The default setting of first-order basis functions is applicable to most antenna problems. For models that contain large volumes of homogeneous material such as air, the use of second-order basis functions may be more efficient. Mixed order basis functions introduced in HFSS v12 are ideal for problems that have large spaces and small details.

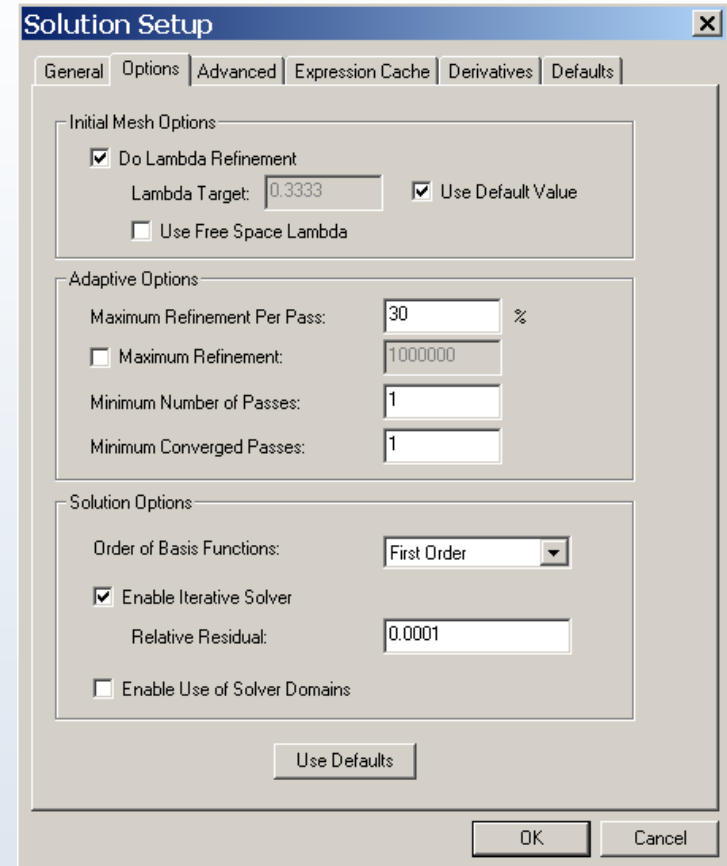



# Solution Setup (3): Frequency Sweep Type



- **Discrete frequency sweep:** The discrete frequency sweep solves the adapted mesh at each user-specified frequency. This is the most accurate method, but the runtime scales linearly with the number of frequencies. This sweep type provides fields and S-parameters for each frequency point.
- **Fast frequency sweep:** The fast frequency sweep typically produces valid results over bandwidth of several octaves. Set the adaptive mesh near or at the center of the desired band since the field solution is extrapolated around the solved frequency. This sweep type provides fields and S-parameters for each frequency point.
- **Interpolating frequency sweep:** The interpolating sweep is applicable to narrowband as well as very wideband sweeps. This sweep type solves the adapted mesh at the start, stop and midpoint of the frequency range and iteratively adds frequency points in order to create a curve-fit for all complex S-parameters. This sweep type provides only S-parameters for each frequency point and the field at the solution frequency.

Sweep Type	Speed	# of Freq. Points*	Bandwidth Limit†	Saved Fields	Memory	Adaptive Frequency
Discrete	Slow for many frequency points	10's	None	All Frequencies	Same as Last Adaptive	Highest In-band Frequency
Fast	<ul style="list-style-type: none"> <li>• Fast for large sweeps</li> <li>• Can be slower for small sweeps</li> </ul>	<10,000	Octave	All Frequencies	More than Last Adaptive	Center of Frequency Band
Interpolating	Fast	<10,000	None	Only Last Adaptive	Same as Last Adaptive	Highest In-band Frequency

# Post Processing: Edit Sources



- **Edit Sources:** Edit sources is a post processing operation that sets complex power scaling factors for each port
  - Access through menu option **HFSS** → **Fields** → **Edit Sources**
- The coefficients specified are only used in post-processing operations. The scaling factor used under edit sources will not affect passive s-parameter results
  - **E, H, and J fields on 3D geometry**
  - **Far-field plots (patterns)**
  - **Active S-parameters**

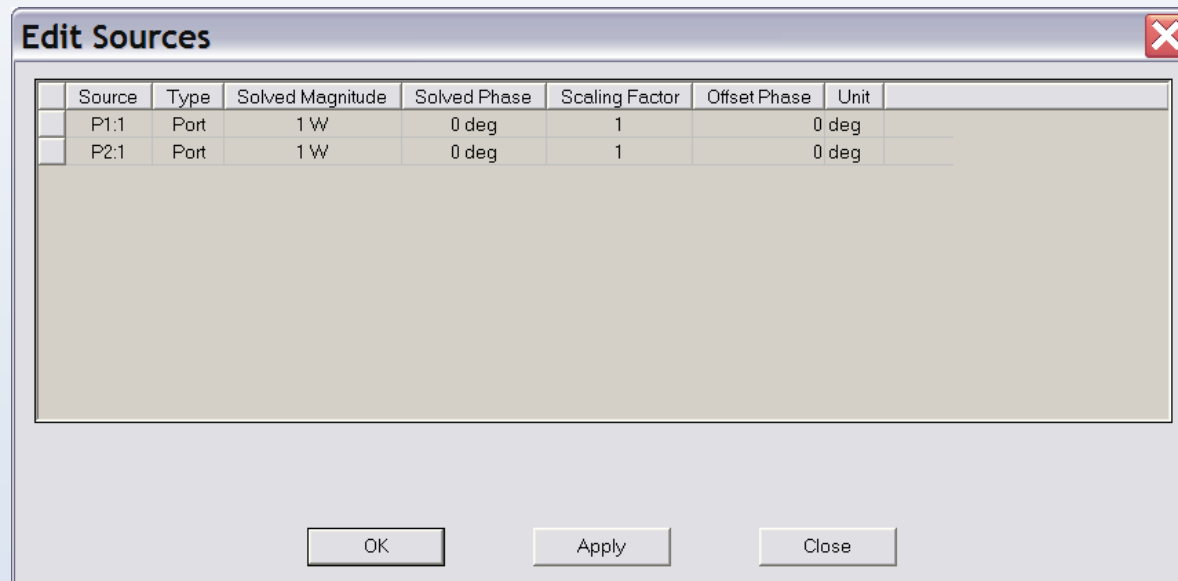

# Post Processing: Far Field Definitions



- **Active S-Parameters:** Active S-parameters includes all mutual coupling from other ports to produce an “active S11” response at a given port. Passive S-parameters assume all other ports are loaded in terminal impedance and there are no reflections from other terminated ports. Active S-parameters represent port response based on coupled signals from other ports and includes coupling from other ports.
- **Total Gain vs. Realized Gain:** Total Gain is four pi times the ratio of an antenna’s radiation intensity in a given direction to the total power accepted by the antenna. Realized gain is four pi times the ratio of an antenna’s radiation intensity in a given direction to the total power incident upon the antenna port(s). Realized Gain includes the impedance mismatch loss associated with the antenna feed.
- **Polarization:** The electromagnetic field which is radiated by an antenna into the far field can be decomposed into various orthogonal polarization components. The following commonly used definitions are based on the direction of the electric field vector as the wave propagates through space: Right Hand Circular Polarization (RHCP), Left Hand Circular Polarization (LHCP), Theta-Polarized, Phi-Polarized and X,Y,Z –Polarized. Complete descriptions of these quantities are available in the HFSS help documentation.

$$Active S_{p:m} = \sum_{k=1}^n \left[ \frac{a_{k:m}}{a_{p:m}} \times S_{p:k} \right]$$

$$Total\ Gain = \frac{4\pi \cdot U}{Accepted\ Power}$$

$$Realized\ Gain = \frac{4\pi \cdot U}{Incident\ Power}$$

# Post Processing: Trace Characteristics



- Radiation trace characteristics can be applied to any 2D radiation plot to quickly obtain beamwidth for any dB threshold (3 dB, etc.) and sidelobe levels and locations
  - Right-click on pattern report to activate menu

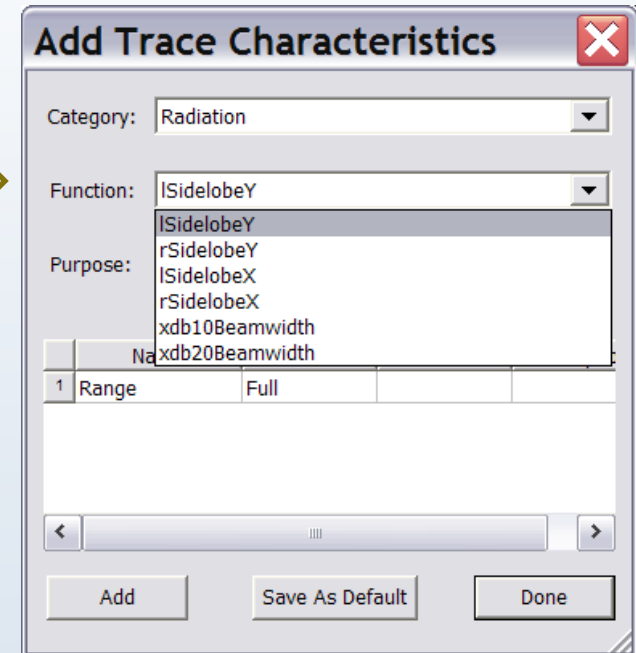
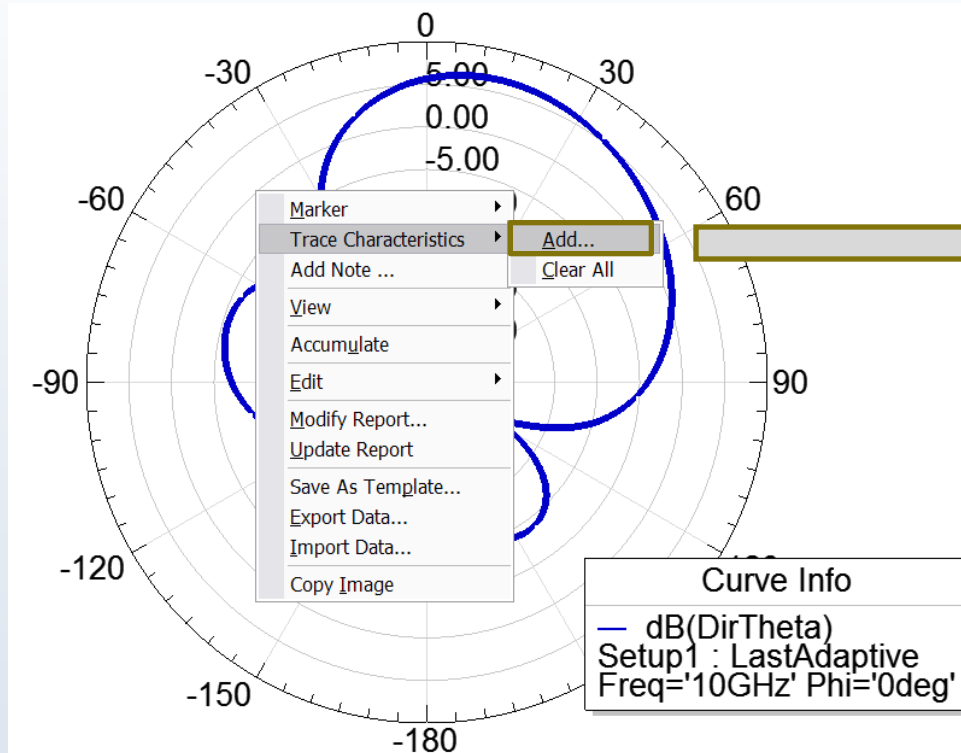

## 射频和天线设计培训课程推荐

易迪拓培训([www.edatop.com](http://www.edatop.com))由数名来自于研发第一线的资深工程师发起成立,致力并专注于微波、射频、天线设计研发人才的培养;我们于 2006 年整合合并微波 EDA 网([www.mweda.com](http://www.mweda.com)),现已发展成为国内最大的微波射频和天线设计人才培养基地,成功推出多套微波射频以及天线设计经典培训课程和 ADS、HFSS 等专业软件使用培训课程,广受客户好评;并先后与人民邮电出版社、电子工业出版社合作出版了多本专业图书,帮助数万名工程师提升了专业技术能力。客户遍布中兴通讯、研通高频、埃威航电、国人通信等多家国内知名公司,以及台湾工业技术研究院、永业科技、全一电子等多家台湾地区企业。

易迪拓培训课程列表: <http://www.edatop.com/peixun/rfe/129.html>



### 射频工程师养成培训课程套装

该套装精选了射频专业基础培训课程、射频仿真设计培训课程和射频电路测量培训课程三个类别共 30 门视频培训课程和 3 本图书教材;旨在引领学员全面学习一个射频工程师需要熟悉、理解和掌握的专业知识和研发设计能力。通过套装的学习,能够让学员完全达到和胜任一个合格的射频工程师的要求...

课程网址: <http://www.edatop.com/peixun/rfe/110.html>

### ADS 学习培训课程套装

该套装是迄今国内最全面、最权威的 ADS 培训教程,共包含 10 门 ADS 学习培训课程。课程是由具有多年 ADS 使用经验的微波射频与通信系统设计领域资深专家讲解,并多结合设计实例,由浅入深、详细而又全面地讲解了 ADS 在微波射频电路设计、通信系统设计和电磁仿真设计方面的内容。能让您在最短的时间内学会使用 ADS,迅速提升个人技术能力,把 ADS 真正应用到实际研发工作中去,成为 ADS 设计专家...



课程网址: <http://www.edatop.com/peixun/ads/13.html>



### HFSS 学习培训课程套装

该套课程套装包含了本站全部 HFSS 培训课程,是迄今国内最全面、最专业的 HFSS 培训教程套装,可以帮助您从零开始,全面深入学习 HFSS 的各项功能和在多个方面的工程应用。购买套装,更可超值赠送 3 个月免费学习答疑,随时解答您学习过程中遇到的棘手问题,让您的 HFSS 学习更加轻松顺畅...

课程网址: <http://www.edatop.com/peixun/hfss/11.html>

## CST 学习培训课程套装

该培训套装由易迪拓培训联合微波 EDA 网共同推出,是最全面、系统、专业的 CST 微波工作室培训课程套装,所有课程都由经验丰富的专家授课,视频教学,可以帮助您从零开始,全面系统地学习 CST 微波工作的各项功能及其在微波射频、天线设计等领域的设计应用。且购买该套装,还可超值赠送 3 个月免费学习答疑...

课程网址: <http://www.edatop.com/peixun/cst/24.html>



## HFSS 天线设计培训课程套装

套装包含 6 门视频课程和 1 本图书,课程从基础讲起,内容由浅入深,理论介绍和实际操作讲解相结合,全面系统的讲解了 HFSS 天线设计的全过程。是国内最全面、最专业的 HFSS 天线设计课程,可以帮助您快速学习掌握如何使用 HFSS 设计天线,让天线设计不再难...

课程网址: <http://www.edatop.com/peixun/hfss/122.html>

## 13.56MHz NFC/RFID 线圈天线设计培训课程套装

套装包含 4 门视频培训课程,培训将 13.56MHz 线圈天线设计原理和仿真设计实践相结合,全面系统地讲解了 13.56MHz 线圈天线的工作原理、设计方法、设计考量以及使用 HFSS 和 CST 仿真分析线圈天线的具体操作,同时还介绍了 13.56MHz 线圈天线匹配电路的设计和调试。通过该套课程的学习,可以帮助您快速学习掌握 13.56MHz 线圈天线及其匹配电路的原理、设计和调试...

详情浏览: <http://www.edatop.com/peixun/antenna/116.html>



### 我们的课程优势:

- ※ 成立于 2004 年,10 多年丰富的行业经验,
- ※ 一直致力并专注于微波射频和天线设计工程师的培养,更了解该行业对人才的要求
- ※ 经验丰富的一线资深工程师讲授,结合实际工程案例,直观、实用、易学

### 联系我们:

- ※ 易迪拓培训官网: <http://www.edatop.com>
- ※ 微波 EDA 网: <http://www.mweda.com>
- ※ 官方淘宝店: <http://shop36920890.taobao.com>